

INTERSTITIAL SPACE NOTE:

ENTIRE INTERSTITIAL CAVITY TO BE FILLED W/ NON-COMBUSTIBLE INSULATION BY G.C.
 PER NFPA #13, SECTION 8.15.1.2.7
 SPINKLER PROTECTION IS NOT REQUIRED

HANGER SPACING CHART						
PIPE TYPE	1"	1 1/4"	1 1/2"	2"	2 1/2"	3"
BLACK STEEL SCH. 10	12'-0"	12'-0"	15'-0"	15'-0"	15'-0"	15'-0"
BLACK STEEL SCH. 40	12'-0"	12'-0"	15'-0"	15'-0"	15'-0"	15'-0"
CPVC	6'-0"	6'-0"	7'-0"	8'-0"	9'-0"	10'-0"

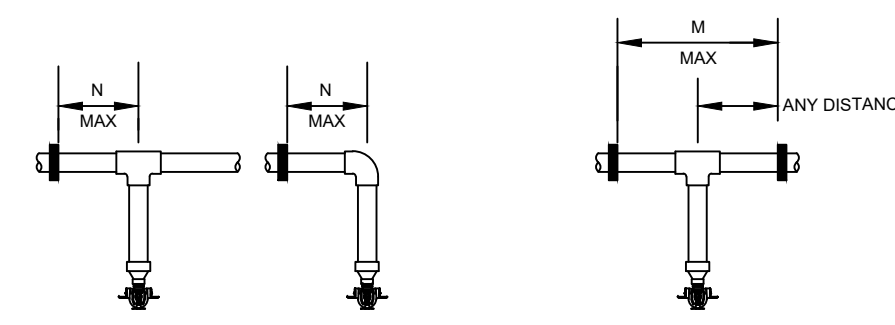
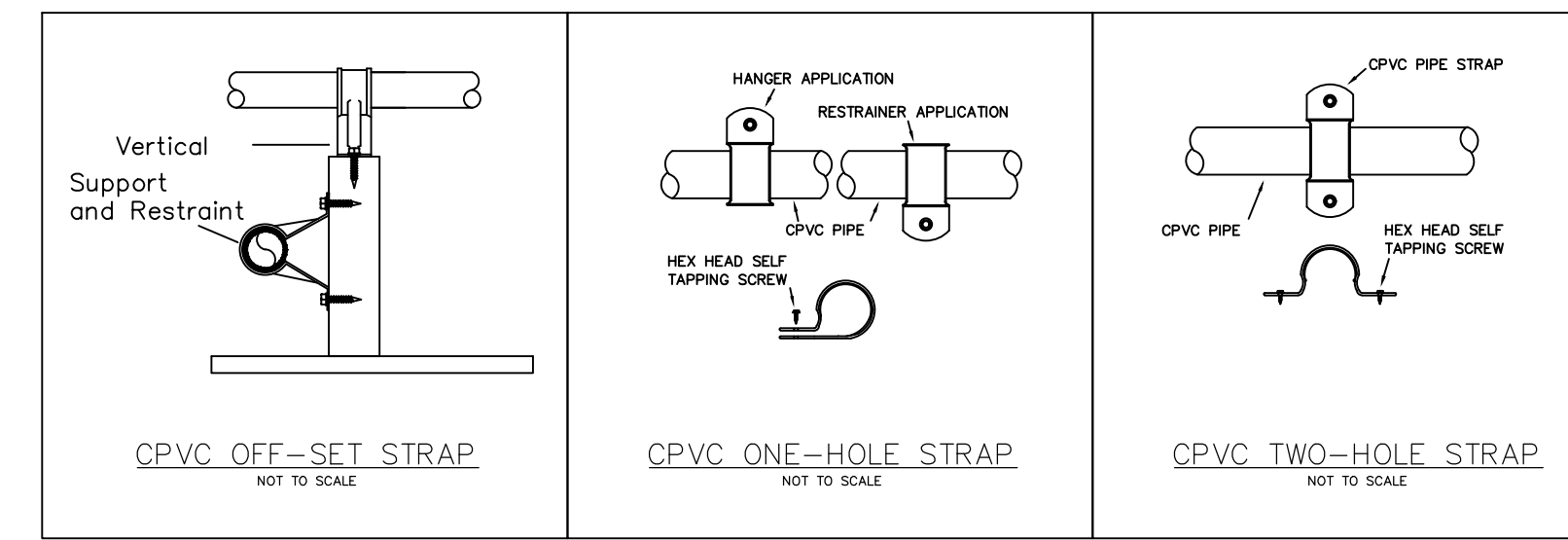
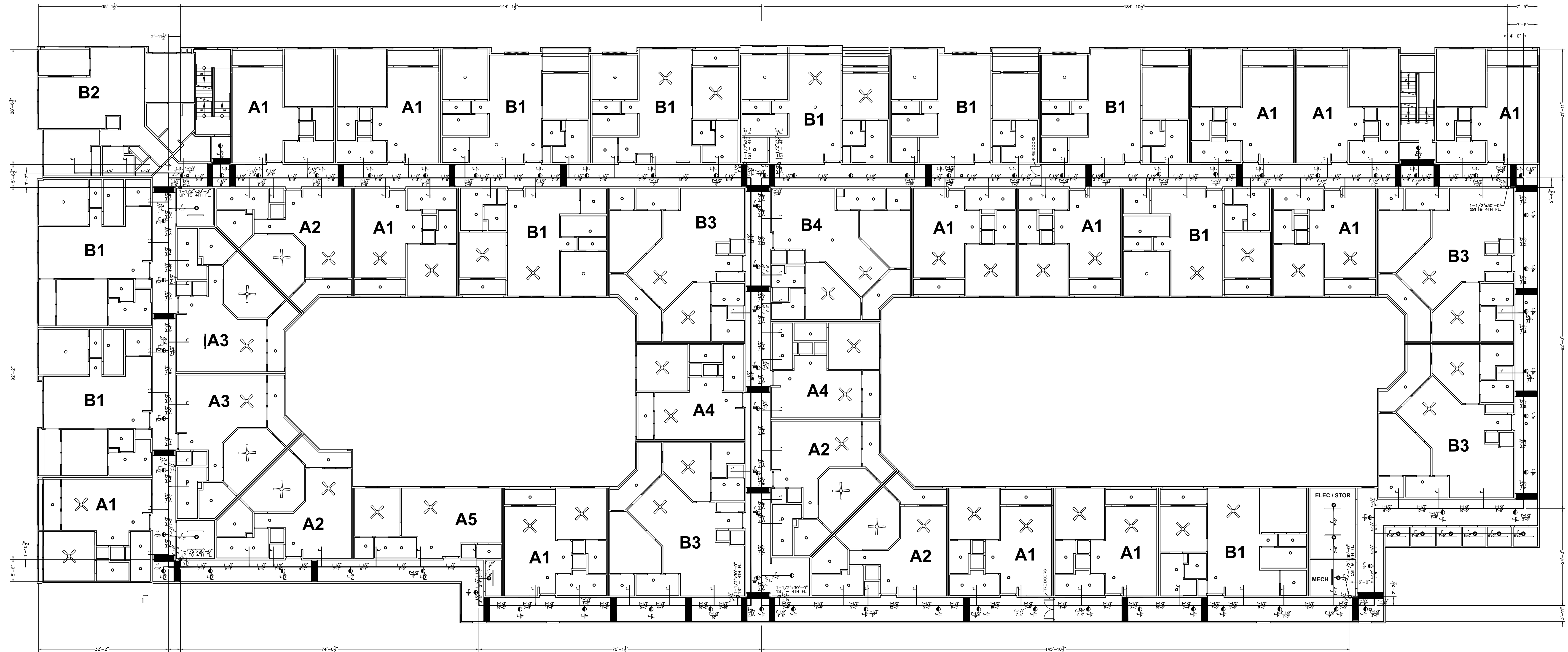
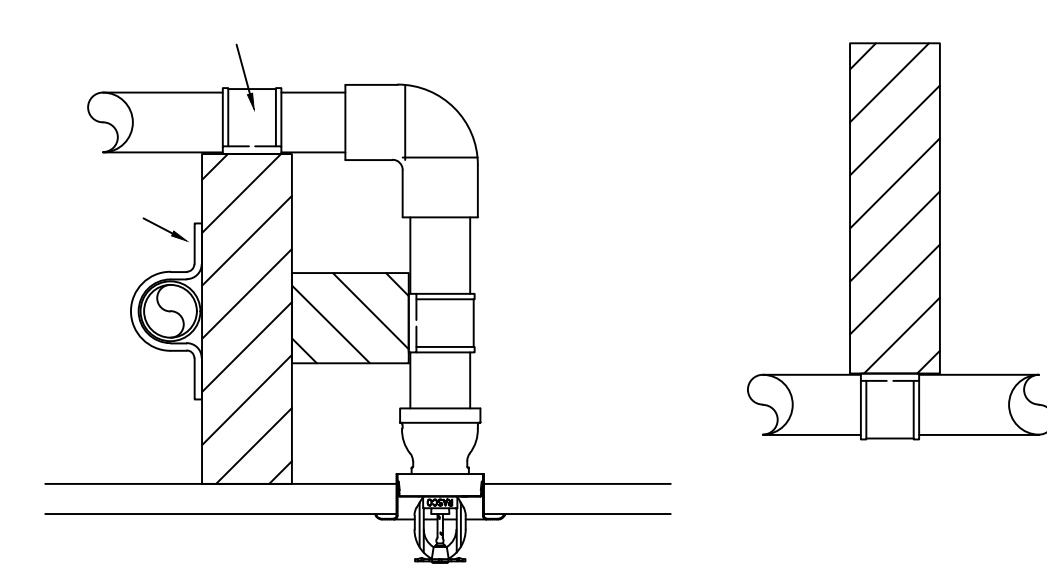

TABLE - R ONE POINT RESTRAINT			TABLE - S TWO POINT RESTRAINT		
NOMINAL PIPE SIZE	1/4"	3/8"	NOMINAL PIPE SIZE	1/4"	3/8"
LESS THAN 100 PSI	0'-0"	0'-0"	LESS THAN 100 PSI	0'-0"	0'-0"
100 PSI	0'-0"	0'-0"	100 PSI	0'-0"	0'-0"
150 PSI	0'-0"	0'-0"	150 PSI	0'-0"	0'-0"
200 PSI	0'-0"	0'-0"	200 PSI	0'-0"	0'-0"

BRANCH LINES SHALL BE BRACED AT A DISTANCE FROM A TEE OR ELBOW TO PREVENT LIFT OF SPRINKLERS AS SHOWN IN TABLES "R" OR "S".



AREAS		SPRINKLER HEAD	MAX. SPACING	MAX. DISTANCE OFF WALL
RESIDENTIAL - CORRIDOR		TYCO EC-8 8.6K RECESSED PENDENT	18' x 18' = 324 SQ. FT.	5'-0"
RESIDENTIAL - MECHANICAL / ELECTRIC (ALL FLOORS)		TYCO PR8 8.6K RECESSED PENDENT	18' x 18' = 324 SQ. FT.	5'-0"
RESIDENTIAL - UNITS LEVELS 1 - 5 (ROOMS)		TYCO SERIES LPI 8.6K RESIDENTIAL PENDENT	18' x 18' = 324 SQ. FT.	5'-0"
RESIDENTIAL - UNITS LEVELS 1 - 5 (EXTERIOR BALCONY)		GLOBE GL-1 1" NPT 5.6K RESIDENTIAL DRY SIDEWALL	18' x 18' = 324 SQ. FT.	5'-0"



2ND FLOOR - 41,400 SQ.FT.

SCALE: 3/32" = 1'-0"
 INSTALL PIPING @ 11'-0" O.C. AFF

NICET Level IV Automatic Sprinkler System Layout Certification #79357
 Richard P. Kossler

1444 HOME STREET
 Jacksonville, Florida
 LEVEL 2 SPRINKLER

SWIFT
 Southeast Fire Protection
 2220 COUNTY RD. 210 WEST
 SUITE NO. 108-139
 JACKSONVILLE, FL 32259
 PH: 904-452-5237

REVISIONS & APPROVALS	
NO.	DATE
1	11/27/18

SYMBOL	DESCRIPTION
○	SPRINKLER HEAD
○	TYCO EC-8 8.6K RECESSED PENDENT
○	TYCO PR8 8.6K RECESSED PENDENT
○	TYCO SERIES LPI 8.6K RESIDENTIAL PENDENT
○	GLOBE GL-1 1" NPT 5.6K RESIDENTIAL DRY SIDEWALL

SCALE: 3/32" = 1'-0"
 JOB NUMBER: 698
 DATE: 10/30/2018